

Products

- CCTV
- Access Control
- ANPR
- Visitor Management
- Panic Alarm Systems
- Interview Recording

Markets

- Marine
- Oil & Gas
- Law Enforcement
- Parking
- Security



Marine Camera Housing

Camera housing

BSOA0000067

Fully cable managed Camera Housing, including wall bracket and 12V DC/24V AC heater. Ruggedised marine finish. The BSA0067 is a tough, fixed camera housing which seals against dirt, moisture and dust ingress. It allows a wide range of fixed cameras and lenses to be used in tough, outdoor environments. It is IP67 weather-proof rated and IK10 shock and vandal-resistant. It can be pendant or pedestal mounted to ceilings, walls and soffits.



Features

- Tough, vandal-resistant housing, IK10 & IP67
- Ruggedised Marine grade
- PoE+, 24VAC or 12VDC
- Wide range of camera & lens options
- Camera/lens options can be factory fitted if required
- Custom colours available
- Marine powder coat paint gives a robust, UV light-stable finish
- Fully cable-managed solution, keeps cables hidden and secure
- No need for additional junction box
- Wall-bracket, pendant or pedestal mount options
- Extendable sun/rain visor option
- Manufactured in the United Kingdom

Products

- CCTV
- Access Control
- ANPR
- Visitor Management
- Panic Alarm Systems
- Interview Recording

Markets

- Marine
- Oil & Gas
- Law Enforcement
- Parking
- Security

Technical Specifications

BSOA0000067

Window	Toughened Glass
Power supply	PoE+, 12VDC or 24VAC
Power consumption	36W (12VDC); 72W (24VAC)
Impact protection	IK10
Ingress protection	IP67
European/US/EMC	CE/FCC
Material	Die Cast Aluminium
Colour	RAL 7035 light grey (standard)
Operating temp	-20 to +55 deg C
Atmospheric pressure	20mm conduit access
Weight (kg)	3.7kg including bracket
Dimensions - external (mm)	358L x 152W x 309H (pedestal); 420L x 152W x 369H (wall)
Dimensions - internal (mm)	L 290mm x W 79mm x H103mm
Cable entry	Base/ 20mm conduit access 2x 20mm internal glands
Mounting options	Wall hanging, fixed bracket , pedestal base

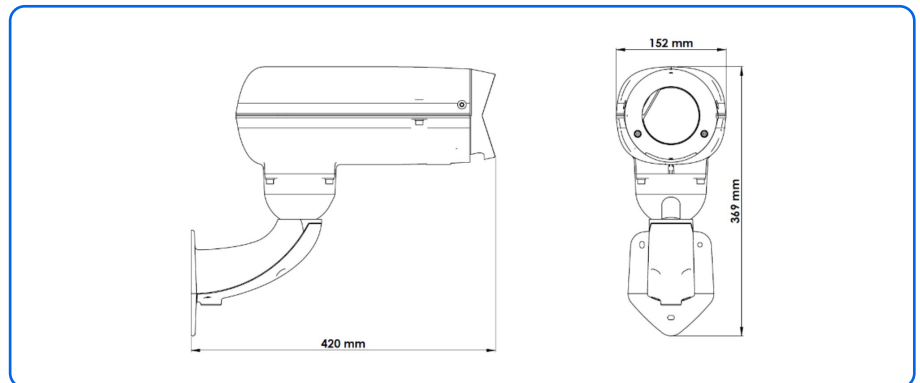

**For more information on any of our products
or services please contact:**

Paragon Security Limited

Unit 14, Bentalls Business Park, Colchester
Road, Maldon, Essex CM9 4GD UK

+44 (0)1245 210914

info@paragon-security.com

paragon-security.com