

Products

- CCTV
- Access Control
- ANPR
- Visitor Management
- Panic Alarm Systems
- Interview Recording

Markets

- Marine
- Oil & Gas
- Law Enforcement
- Parking
- Security



Marine Camera Housing With Wiper (& Washer Option)

Camera housing

BSOA000W067

Marine camera housing with wiper (& washer option). Long life silicone wiper with auto-wipe and/or remote wash/wipe control facility. Wash/wipe intervals can be set using remote control or dip-switch. Fully cable managed Camera Housing, including wall bracket and 12V DC/24V AC heater. Ruggedised marine finish. It is a tough, fixed camera housing which seals against dirt, moisture and dust ingress. It allows a wide range of fixed cameras and lenses to be used in tough, outdoor environments. It is IP67 weather-proof rated and IK10 shock and vandal-resistant. It can be pendant or pedestal mounted to ceilings, walls and soffits.

The system includes a nozzle to squirt water onto the camera's window. This is cleaned away by the camera's silicon wiper. This connects to the washer pipe of the wash pump system (OSTANKAABB and OSWASH). The washer pump motor can be switched on via an open/close contact or a telemetry control command. The nozzle bracket is made from Marine Grade, 316, stainless steel for exceptional resistance to extreme marine, hazardous and toxic environments."



Features

- Tough, vandal-resistant housing, IK10 & IP67
- Ruggedised Marine grade
- PoE+, 24VAC or 12VDC
- Wide range of camera & lens options
- Camera/lens options can be factory fitted if required
- Custom colours available
- Marine powder coat paint gives a robust, UV light-stable finish
- Fully cable-managed solution, keeps cables hidden and secure
- No need for additional junction box
- Wall-bracket, pendant or pedestal mount options
- Extendable sun/rain visor option
- Manufactured in the United Kingdom
- Long life silicone wiper
- Washer option with remote control (WPN400)

Products

- CCTV
- Access Control
- ANPR
- Visitor Management
- Panic Alarm Systems
- Interview Recording

Markets

- Marine
- Oil & Gas
- Law Enforcement
- Parking
- Security

Technical Specifications

BSOA000W067

Window	Toughened Glass
Power supply	PoE+, 12VDC or 24VAC
Power consumption	10.8W (12VDC); 6.6W (24VAC); 13W PoE
Impact protection	IK10
Ingress protection	IP67
European/US/EMC	CE/FCC
Material	Die Cast Aluminium
Colour	RAL 7035 light grey (standard)
Operating temp	-20 to +55 deg C
Atmospheric pressure	20mm conduit access
Weight (kg)	4.2kg including bracket
Dimensions - external (mm)	358L x 152W x 309H (pedestal); 420L x 152W x 369H (wall)
Dimensions - internal (mm)	L 228mm x W 79mm x H103mm
Cable entry	Base/ 20mm conduit access 1× 20mm Split Gland; 1× 20mm standard gland
Mounting options	Wall hanging, fixed bracket , pedestal base

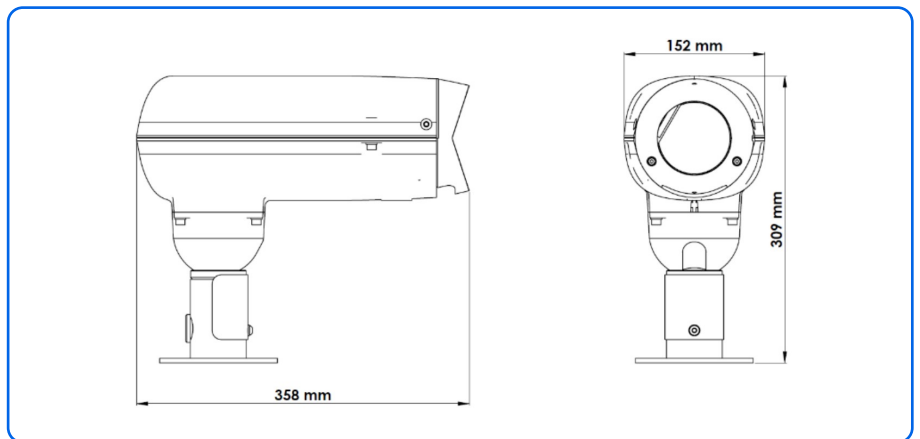

**For more information on any of our products
or services please contact:**

Paragon Security Limited

Unit 14, Bentalls Business Park, Colchester
Road, Maldon, Essex CM9 4GD UK
+44 (0)1245 210914
info@paragon-security.com
paragon-security.com