

Products

- CCTV
- Access Control
- ANPR
- Visitor Management
- Panic Alarm Systems
- Interview Recording

Markets

- Marine
- Oil & Gas
- Law Enforcement
- Parking
- Security



External 5MP PTZ Camera

Commercial

PSOA5Z30II66

This is an IR speed dome camera (PTZ) with 5MP resolution - excellent for video surveillance in wide coverage areas. It is equipped with 200M IR illuminators and a 30x optical zoom to optimise detail in any scene. The smart IR technology allows broad coverage FOV and highly uniform IR intensity while avoiding hotspots. The camera's built-in Smart Tracking allows the user to identify and track the person of interest automatically in real time.

The 5MP PTZ Ultra PoE dome CCTV camera is a rugged and easy to install IP camera designed for use on maritime vessels. These cameras offer a highly robust, feature rich, speed dome solution for extreme environment applications such as engine rooms, workshops and machinery spaces.

The camera head uses a 2560x1920 high-resolution and low light colour/mono sensor & IR cut filter for seamless day/night operation with 30x optical zoom. Other features include proportional pan and tilt speed control, time stamp and switchable tilt flip operation. The integrated IP camera can deliver four simultaneous video streams including the latest H.265 video compression format option which drastically reduces bandwidth and storage requirements without compromising image quality. The ONVIF compliant camera can easily be integrated into standard IP network systems. Multiple Ultra PoE cameras have the option of being integrated with a suitable Ultra PoE compatible network switch, thus removing the need for additional power supplies / junction boxes and simplifying installation.

The advanced marine camera also features Wide Dynamic Range, autofocus, and integrated Smart IR illuminators with a range of up to 200m. Further the waterproof IP66-rated, vandal-proof IK10 and NEMA 4X rated housing protects the camera body against rain, dust & corrosion and provides a wide operating temperature range of between -40°C to 60°C. The rugged PTZ camera is supplied as a complete camera station including wall/bulkhead mounti...



Products

- CCTV
- Access Control
- ANPR
- Visitor Management
- Panic Alarm Systems
- Interview Recording

Markets

- Marine
- Oil & Gas
- Law Enforcement
- Parking
- Security

Features

- 25 fps @ 2560x1920
- 30x Optical Zoom, Auto Focus
- 360° Continuous Pan, -20° to 90° (auto flip) Tilt
- 200M IR with Smart IR
- Weather-proof IP66-rated, Vandal-proof IK10 and NEMA 4X-rated Housing
- -40°C ~ 60°C Wide Temperature Range for Extreme Weather Conditions
- EIS (Electronic Image Stabilization) for Image Stability
- Smart Tracking Advanced for Moving People with People-based Deep Learning Technology
- Suited to harsh environmental conditions including petrochemicals, mining, military, medicine, oil & gas, marine, drilling platforms, food processing and storage, offshore etc.

Technical Specifications

PSOA5Z30II66

Sensor	1/2.8" Progressive CMOS
Resolution	5MP
Pixels	2560x1920
Frame rate	25 fps
Sensitivity	0.03 lux @ F1.3 (colour); 0.005 lux @ F1.3 (B/W); 0 lux with IR
Optical Lens	4.94 ~ 148.24 mm 30x Optical Zoom, Auto Focus
Digital zoom	32x digital zoom (4x on IE plug-in, 8x built in)
Aperture range	F1.3 ~ F4.6
Horizontal viewing angle	54.1° ~ 1.9° (Horizontal)
Focusing mode	Remote focus, remote zoom
IR Illumination range	200m
On-board storage (option)	Seamless Recording to MicroSD/SDHC/SDXC card and recording to network-attached storage (NAS)
Wide Dynamic Range	120 dB
Signal to Noise ratio	74 dB
Analytics	Smart VCA
Video compression	H.265, H.264, MJPEG
Support protocols	802.1X, ARP, Bonjour, CIFS/SMB, DDNS, DHCP, DNS, FTP/SFTP, HTTP, HTTPS, ICMP, IGMPv3, IPv4, IPv6, NTCIP, NTP, PPPoE, QoS (CoS/DSCP), RTSP/RTP/RTCP, SMTP, SNMP, SSL, TCP/IP, TLS 1.2, UDP, UPnP

Products

- CCTV
- Access Control
- ANPR
- Visitor Management
- Panic Alarm Systems
- Interview Recording

Markets

- Marine
- Oil & Gas
- Law Enforcement
- Parking
- Security

Interface protocols	Profile G, S, T supported, specification available at www.onvif.org
Pan range	360° endless
Pan speed	0.05° to 450°/sec
Tilt range	-20° to 90° (auto flip)
Tilt speed	0.05° to 450°/sec
Pre-sets	256
Audio connection	Two-way audio (Full duplex); External line input
Audio compression	G.711, G.726
Ethernet	RJ45
Alarm in/out	Audio detection, camera tampering detection, cybersecurity events (brute force attack event, cyberattack event, quarantine event), digital input, manual trigger, motion detection, periodical trigger, recording notification, SD card life expectancy, smart tracking advanced trigger, system boot, preset reached
Power supply	AC 24V, DC 48V, IEEE 802.3 bt Class 6 PoE
Power consumption	PoE: Max. 51W/26W (IR on/off)
Vibration testing	(Designed to) MIL-STD-167-1A Shipboard, 4 to 33Hz
Ingress protection	IP66
European/US/EMC	EMC: CE (EN 55032 Class A, EN55035, EN50121-4), UKCA (BS EN 55032: 2015 +A11: 2020, BS EN 55035: 2017), FCC (FCC Part 15 Subpart B Class A), IC (ICES-003:2020 Issue7, Class A), RCM (AS/NZS CISPR 32 Class A), VCCI (VCCI-CISPR 32 Class A); Safety: UKCA (BS EN 62368-1:2014+A11:2017), UL (UL 62368-1), CB (IEC/EN 62368-1, IEC/EN 60950-22, IEC/EN 62471); Environment: IK10 (IEC 62262), IP66 (IEC 60529), NEMA (NEMA 250 Type 4X); IA: BIS (IS 13252), BSMI

Products

- CCTV
- Access Control
- ANPR
- Visitor Management
- Panic Alarm Systems
- Interview Recording

Markets

- Marine
- Oil & Gas
- Law Enforcement
- Parking
- Security

Material	Aluminium, powder coated
Operating temp	-40°C ~ 60°C (-40°F ~ 140°F) (IR on)
Relative humidity	98% RH (non-condensing)
Weight (kg)	7.1 kg
Dimensions - external (mm)	256 × 336 mm
Mounting options	Wall hanging, fixed bracket , pedestal base
Shock	(Designed to) 30g, 25ms duration, shock handling test

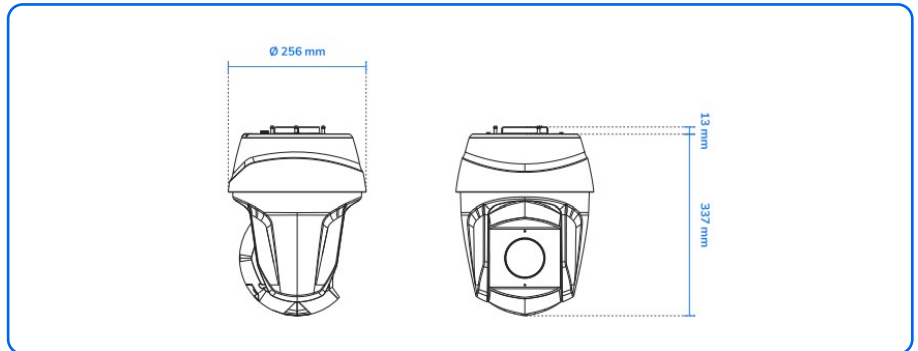

**For more information on any of our products
or services please contact:**

Paragon Security Limited

Unit 14, Bentalls Business Park, Colchester
Road, Maldon, Essex CM9 4GD UK

+44 (0)1245 210914

info@paragon-security.com

paragon-security.com